

Energizer

UE20015CQ

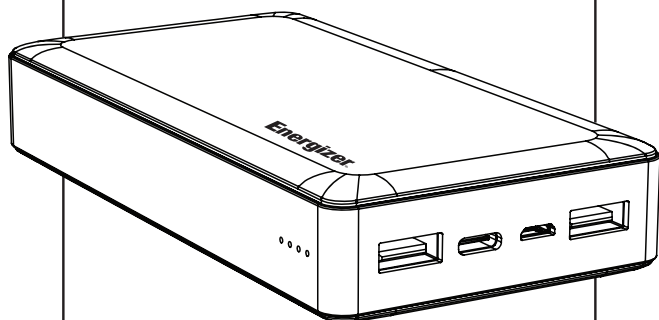

Includes

EN

Specification:

Model Name : UE20015CQ
Battery Cell : Lithium-Polymer
Power Capacity : 20000mAh @3.7V
Output WH : Max.74Wh
Rated Input : Micro USB 5V, 2A (Max.)
/ USB-C : 5V, 3A(Max.)
Rated Output 1 : 5V, 2A
Rated Output 2 : USB-C : Quick Charge
5V/3A, 9V/2A,12V/1.5A (Total 18W Max)
Dimensions : 135.5(L)*70(W)*24.5(H) mm
Weight : 438g±10g

FR

Spécifications:

Modèle : UE20015CQ
Type de batterie : Lithium Polymère
Capacité : 20000mAh @3.7V
Sortie WH : Max.74Wh
Entrée : Micro USB 5V, 2A (Max.)
/ USB-C : 5V, 3A(Max.)
Sortie 1 : 5V, 2A
Sortie 2 : USB-C : Quick Charge 5V/3A,
9V/2A,12V/1.5A (Total 18W Max)
Dimensions : 135.5(L)*70(W)*24.5(H) mm
Poids : 438g±10g

DE

Technische Daten:

Modell : UE20015CQ
Batterie : Lithium Polymer
Lade Kapazität : 20000mAh @3.7V
Ausgangsspannung WH : Max.74Wh
Eingangsspannung : Micro USB 5V, 2A (Max.)
/ USB-C : 5V, 3A(Max.)
Ausgangsspannung 1 : 5V, 2A
Ausgangsspannung 2 : USB-C : Quick Charge
5V/3A, 9V/2A,12V/1.5A (Total 18W Max)
Abmessungen : 135.5(L)*70(W)*24.5(H) mm
Gewicht : 438g±10g

SP

Especificaciones:

Modelo : UE20015CQ
Célula : Polímeros de Litio
Capacidad : 20000mAh @3.7V
Tensión de Salida WH : Max.74Wh
Tensión de Entrada : Micro USB 5V, 2A (Max.)
/ USB-C : 5V, 3A(Max.)
Tensión de Salida 1 : 5V, 2A
Tensión de Salida 2 : USB-C : Quick Charge
5V/3A, 9V/2A,12V/1.5A (Total 18W Max)
Dimensiones : 135.5(L)*70(W)*24.5(H) mm
Peso : 438g±10g

IT

Specifiche tecniche:

Modello : UE20015CQ
Cellula di batteria : Polimero di Litio
Capacità : 20000mAh @3.7V
Potenza WH : Max.74Wh
Ingresso Nominale : Micro USB 5V, 2A (Max.)
/ USB-C : 5V, 3A(Max.)
Potenza Nominale 1 : 5V, 2A
Potenza Nominale 2 : USB-C : Quick Charge
5V/3A, 9V/2A,12V/1.5A (Total 18W Max)
Dimensioni : 135.5(L)*70(W)*24.5(H) mm
Peso : 438g±10g

Package Contents



1 UE20015CQ



3 Micro USB Cable



2 User Manual



4 USB-C Cable



PowerSafe Management

Guarantees against short circuit and over-charging for your power bank and devices.



Register!

Customer Service

For any question about the product, please contact us at service@energizerpowerbanks.com
Please register your product online www.energizerpowerbanks.com/product_registration.php

© 2019 Energizer. Energizer and certain graphic designs are trademarks of Energizer Brands, LLC and related subsidiaries and are used under license by TennRich International Corp. All other brand names are trademarks of their respective owners. Neither TennRich International Corp. nor Energizer Brands, LLC is affiliated with the respective owners of their trademarks.

How to USE

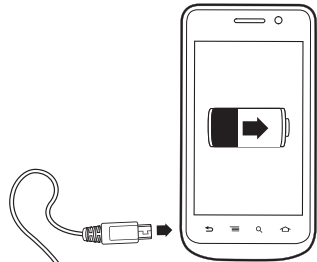
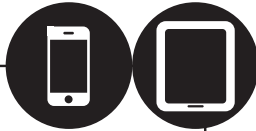

Press the power button to activate charging on your power bank

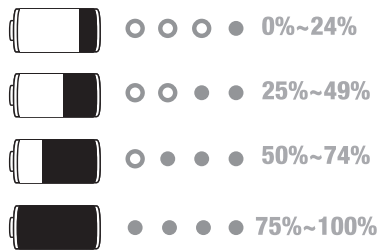
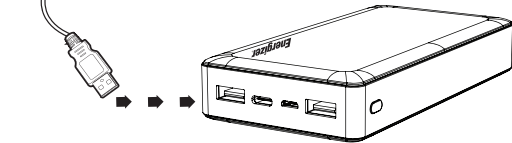

Blinking light indicates recharging.
Solid light indicates fully charged.

How to Recharge

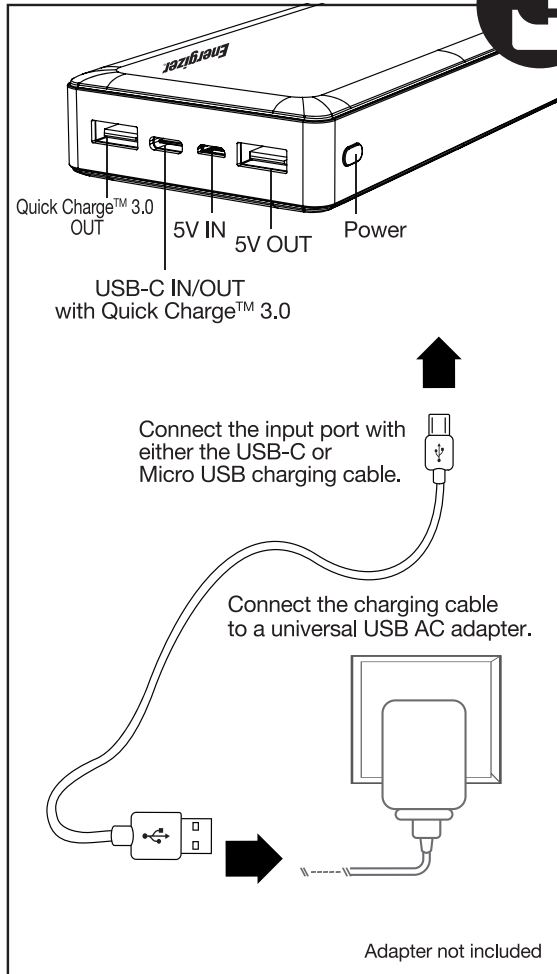

Connect the input port with either the USB-C or Micro USB charging cable.

Connect the charging cable to a universal USB AC adapter.

Safety Instruction

- Avoid water, heat, fire, penetration of the battery, and severe drops at all times.
- Do not insert other objects into the USB ports other than the USB connectors.
- Once the product is fully charged, your power pack automatically shuts off to save power.
- During charge & recharge, battery may feel slightly warm.
- Do not clean the battery with water or other cleaning products, clean the exterior with a lightly wetted cloth or napkin
- Any intentional and physical damage to the battery will not be under the warranty conditions
- Battery storage temperature is between 10°C~60°C , operating temperature is 0°C~45°C
- Fully charge the battery before first use to maximize the battery life
- Recommend to recharge your power bank with a wall charger/adapter.
- For better performance, avoid recharging the power bank while your device is connected to it.

WARRANTY

All products from the date of purchase are qualified for limited time warranty. For more warranty information, please visit: <http://www.energizerpowerbanks.com>

GARANTIE

Alle Produkte eignen sich ab dem Kaufdatum zu einer beschränkten Qualitätsgarantiezeit. Für zusätzliche Garantieinfos klicken Sie bitte auf: <http://www.energizerpowerbanks.com>

GARANZIA

Tous les articles bénéficient d'une garantie limitée dans le temps à partir de la date d'achat. Pour plus d'informations concernant la garantie, merci de visiter notre site : <http://www.energizerpowerbanks.com>

GARANZIA

Tutti i prodotti, a partire dalla data di acquisto, hanno la certificazione sulla qualità per un periodo limitato di tempo. Per ulteriori informazioni sulla garanzia si prega di visitare il sito: <http://www.energizerpowerbanks.com>

GARANTIA

Todos los productos desde la fecha de compra gozan de la garantía de tiempo limitado. Para más información sobre la garantía, puede visitar: <http://www.energizerpowerbanks.com>

Qualcomm Quick Charge is a product of Qualcomm Technologies, Inc. Qualcomm is a trademark of Qualcomm Incorporated, registered in the United States and other countries. Quick Charge is a trademark of Qualcomm Incorporated. All Qualcomm Incorporated trademarks are used with permission.

